

Gold Tec Adjustable Rear Rack

Included Parts List

- A - CARGO TRAY
- B - SHORT LEG EXTENDERS x 2
- C - ROUND HEAD BOLTS x 8
- D - CLAMP RIGS x 2
- E - ADHESIVE PADS x 4
- F - SQUARE WASHERS x 4
- G - LONG LEG EXTENDERS x 2
- H - BUNGEE HOOK HASPS x 2
- I - REAR RIGHT LEG
- J - REAR LEFT LEG
- K - LIGHT / REFLECTOR BRACKET
- L - LONG FLAT HEAD BOLTS, WASHERS AND NUTS x2
- M - SHORT FLAT HEAD BOLT, WASHER AND NUT

Tools Required:

- 4MM ALLEN KEY
- 8MM OPEN WRENCH
- SCISSORS

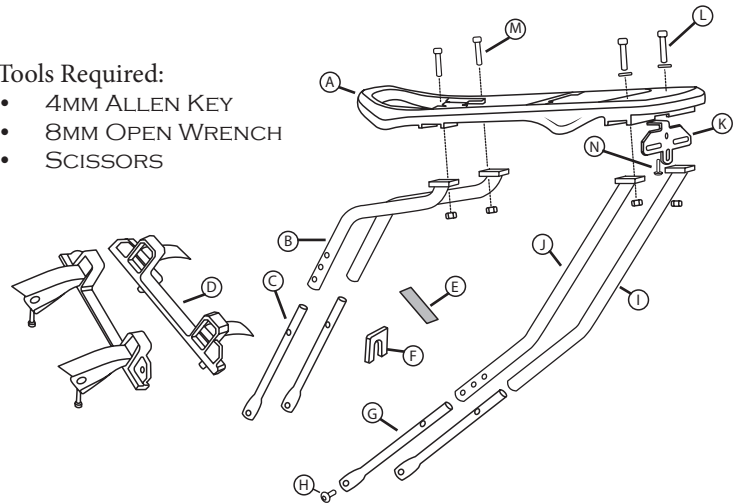

CARRIER ASSEMBLY

1. Attach adhesive pads on both ends of inner surface of seat stay rigs (See fig 2)

2. Attach rear legs to carrier (legs are left and right specific: logo faces out).

Using an allen key and wrench, attach each arm using a long flat head bolt, washer and nut. Leave slightly loose. (See fig 3a or 3b)

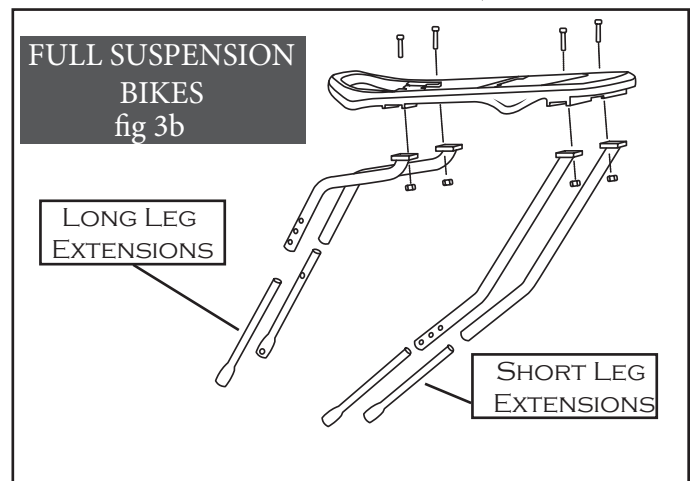
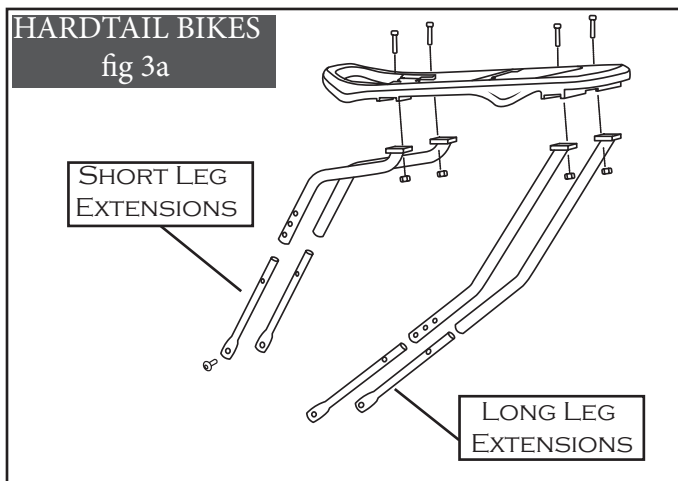
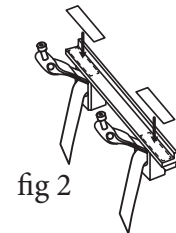

4. Attach clamp rigs and bungee hook hasps to carrier. Logo should face out. For front legs, insert round bolt in front leg bolt hole, then screw into bolt hole on clamp rig. For rear leg, insert round bolt in smallest hole of hasp (hasp angled outwards, facing upward), then screw into bolt hole on clamp rig.

3. Determine leg height. Place carrier over rear wheel and hold legs on seat stays. If cargo tray is not more or less horizontal, remove bolts on front legs, rear legs, or both to adjust carrier height and angle. Carrier must have at least 2 cm clearance over wheel. (fig 4)

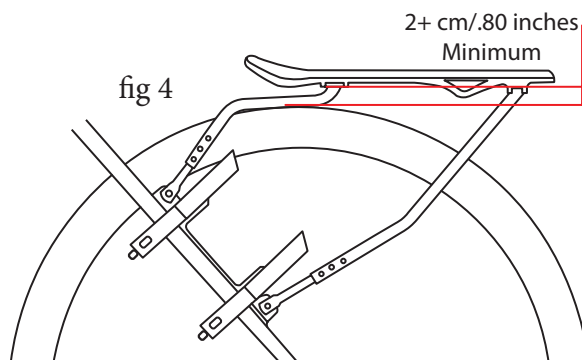

CARRIER MOUNTING

1. Place clamp rigs near the midpoint along the seat stays, seating them on the inner face (fig 5)

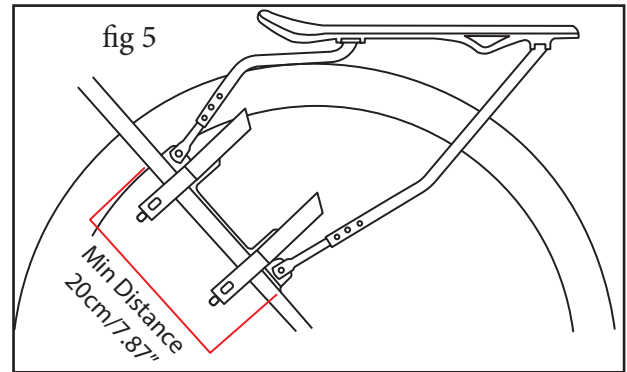

2. Unstick Velcro straps, adjust length (see fig 6), wrap end of strap - with built in allen bolt - around seat stay and push them through the holes in the other side of the clamp.

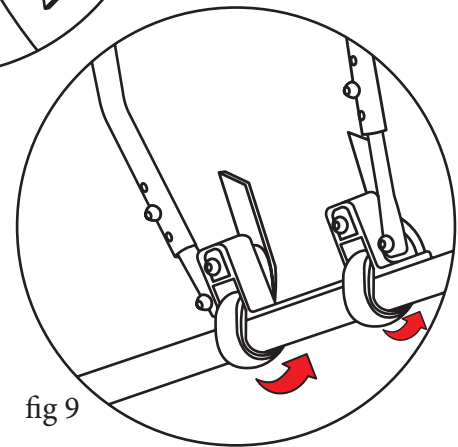
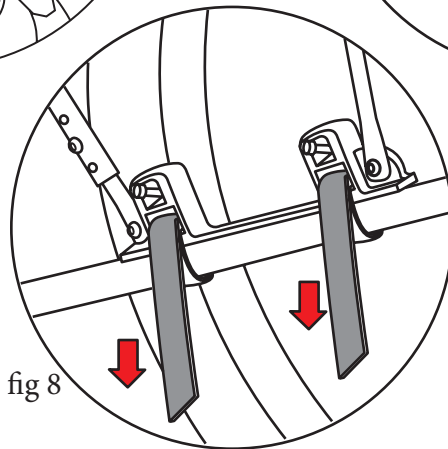
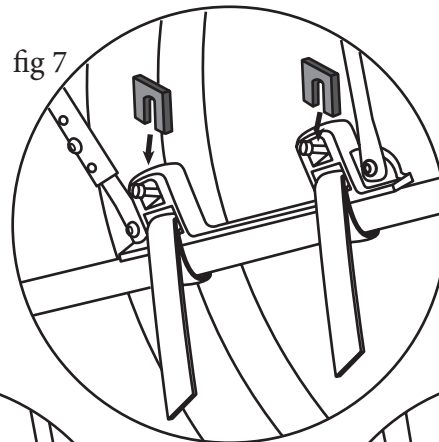
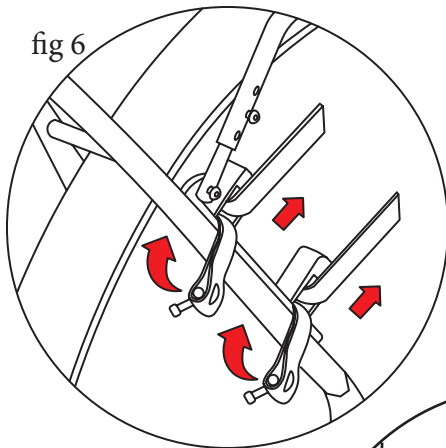

4. Pull down on straps to tighten (see fig 8), and re-stick Velcro all the way around the seat stays (fig 9).

5. Using scissors, cut excess strap that may interfere with the wheel. Tighten bolts.

6. Adjust rear leg position (width) if necessary to center the carrier over the wheel (fig 10).

7. Once carrier is mounted correctly and length and angle adjustments have been made, check and tighten all bolts securely.

